

HILLENG

COLDWIRE UNIT



INTERNATIONAL



The upgraded and fully automated Coldwire Unit uses an abrasive wire band to cut through core insulating materials, including Mineral Wool, PU, PIR, XPS, EPS or Phenoelic Panels. The unit is located after the Cut-Off Unit and linked to the Main Control Console. Photoelectric sensors and servo drives initiate the cutting cycle as the panels move through the unit.

NEW TECHNOLOGY AND DESIGN CHANGES YIELD SUPERIOR PERFORMANCE

- The panel line runs smoothly and never stops.
- New servo technology enables highly accurate, trouble-free operation.
- Faster line speeds and more cutting pattern options are available.
- New photoelectric sensors handle more core materials and colors.
- Mechanical improvements enhance line integration.

Consult your Hilleng representative for the Coldwire Unit suited to your requirements.

BRADBURY GROUP
Australia



Hilleng International

**Bradbury Group
Australia Pty Ltd**

25 Eurora Street
Kingston, QLD 4114
AUSTRALIA

Tel: +61 7 3299 3111

Fax: +61 7 3299 5511

mail@hilleng.com.au

www.hilleng.com.au

HILLENG

COLDWIRE UNIT

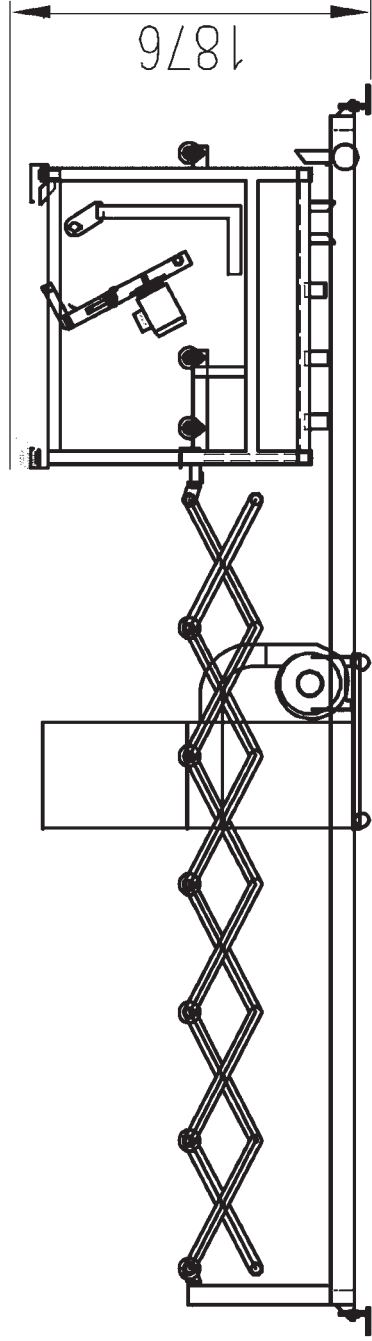
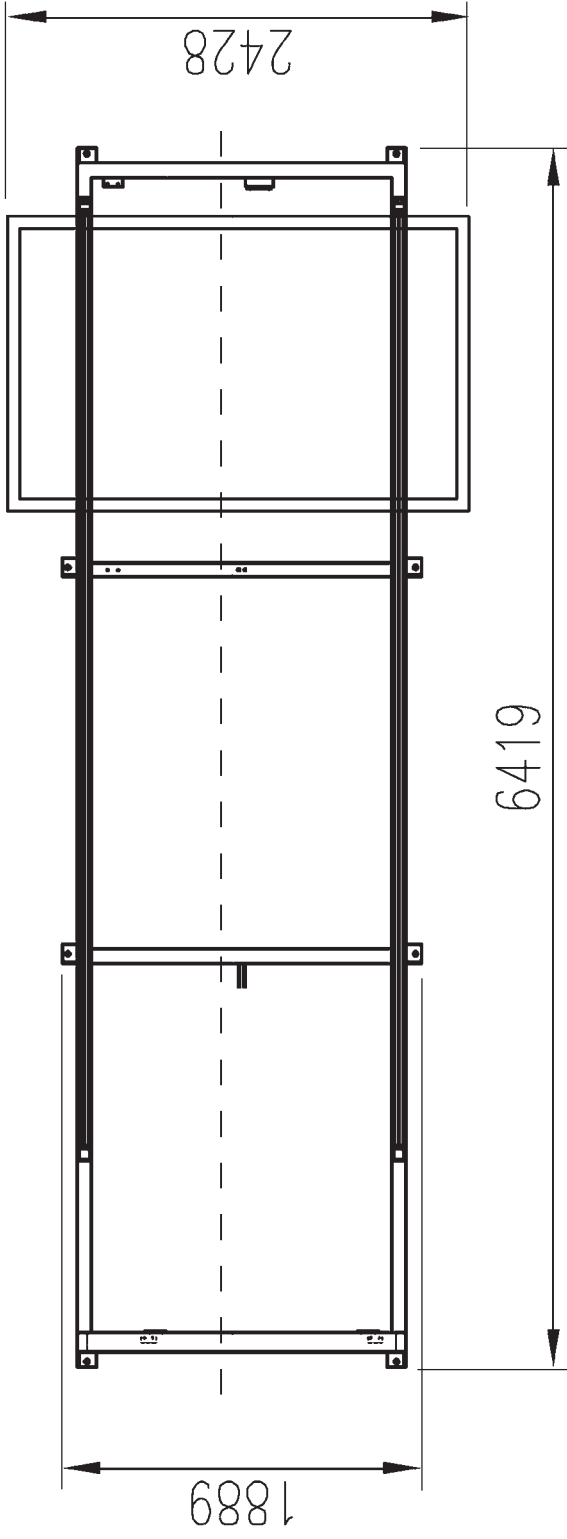

Bradbury Group Australia Pty Ltd

