

HILLENG

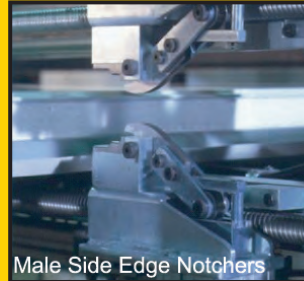

INTERNATIONAL

5 POSITION CUT-OFF UNIT



The **5 Position Cut-Off** *notches the male and female roll-formed edges* of wall panel skin and simultaneously *cuts and forms a safety edge* on the steel skin using specially developed **cutting anvils** – all in a continuous movement and without altering the line speed. The name of the unit refers to the number of different cut patterns the unit can execute.

KEY FEATURES OF THE HILLENG 5 POSITION CUT-OFF UNIT

- Cut-Off is PLC controlled and linkable to the Main Press console.
- Easy touch-screen entry of all batch and cutting parameters.
- Unit precisely follows programmed data in automatic mode.
- Set program for straight cuts, offset/stepped cuts, or *thermal* cuts.

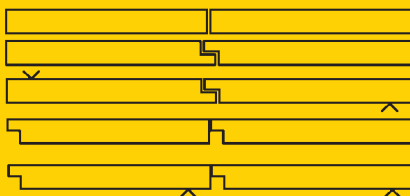

Cut Types

Consult your Hilleng representative for the 5 Position Cut-Off Unit configuration suited to your requirements.

BRADBURY GROUP
Australia



Hilleng International

**Bradbury Group
Australia Pty Ltd**

25 Eurora Street
Kingston, QLD 4114
AUSTRALIA

Tel: +61 7 3299 3111
Fax: +61 7 3299 5511
mail@hilleng.com.au

www.hilleng.com.au

HILLENG

S POSITION CUT-OFF UNIT

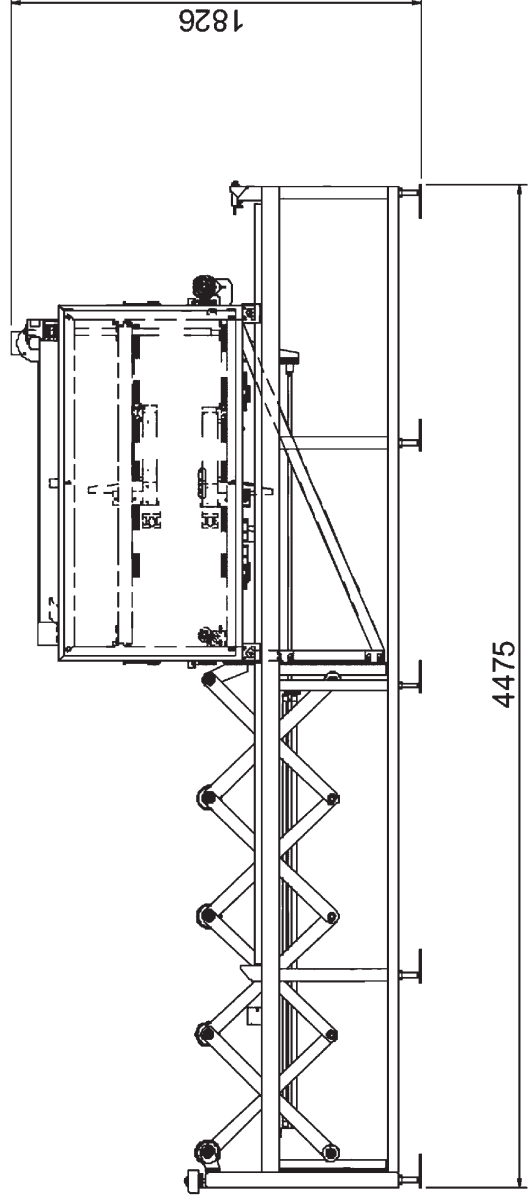
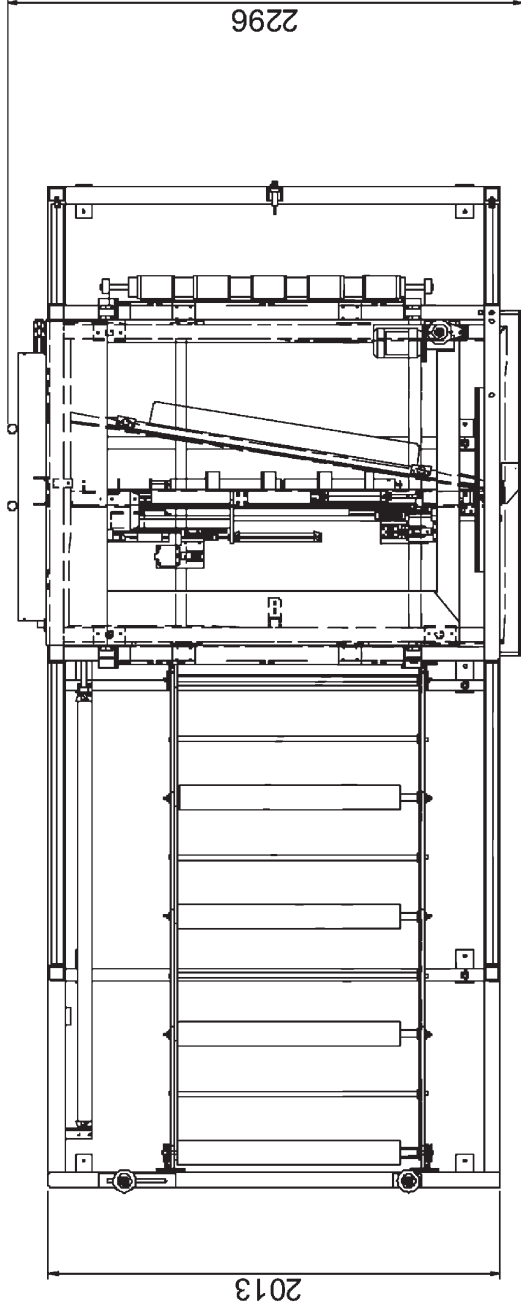

Bradbury Group Australia Pty Ltd

©2011 BRAD-2463

HILLENG International

+61 7 3299 3111 | www.hilleng.com.au

THE BRADBURY GROUP

